

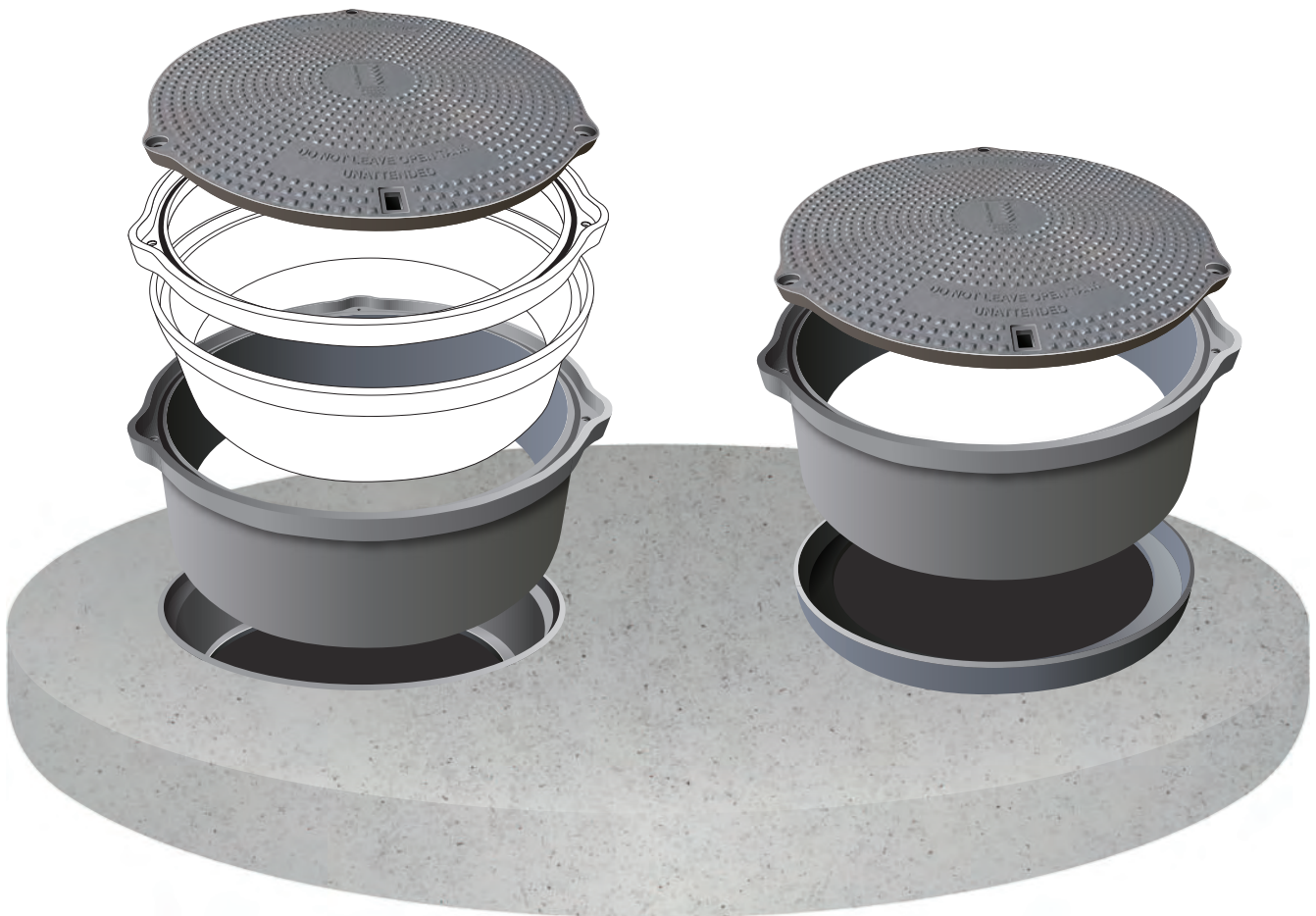

ACCESS COVERS & TURRET RISERS

Application, Options Guide & Pricelist

CONFORCE lightweight access cover and turrets are made of a composite material and can be cast into any concrete tank lid or bolted to any plastic, concrete steel or fibreglass tank. The cover has a water resistant seal and is secured by three stainless steel bolts. It provides a clear 600mm opening into the tank. The cover weighs 9.5kgs and can withstand a load of 1.5 tonnes or a force of 15kN. It is suitable for light traffic areas.



CONTENTS

OVERVIEW <ul style="list-style-type: none">• Product Overview• Features• Benefits	APPLICATION <ul style="list-style-type: none">• Turret assembly for NEW tank lids• Turret assembly for EXISTING tank lids• Components List	OPTIONS FOR NEW TANKS <ul style="list-style-type: none">• Turrets for NEW pre cast tank lids• Options pricelist• Options diagrams (1-13)	OPTIONS FOR EXISTING TANKS <ul style="list-style-type: none">• Turrets for fitting to EXISTING tank lids• Options pricelist• Options diagrams (14-25)	PRICELIST WT SERIES <ul style="list-style-type: none">• Pricelist for Water Tank Series - Components	PRICELIST COVERS & FRAMES <ul style="list-style-type: none">• Unsealed access covers & frames• Cover boxes
--	---	---	--	---	--

Access cover weighs only 9.5kgs.
Load tested to 1.5 tonnes

Stainless steel bolts with covers

Water resistant seal

300mm turret with seal

Leaf basket with 1mm mosquito mesh (basket can support 100kgs)
Only clean water enters the tank
Cut out for pump pipe

Leaf basket support ring



FEATURES
Water resistant
Lightweight access cover is weighs only 9.5kgs. 600mm clear opening to tank. On a weight for weight comparison it is stronger than steel.
Able to support a 1.5 tonne load
Turret height can be increased in 50mm increments
Lockable
Safety minded
Can be customised
Standard colour - grey

BENEFITS
Prevents the ingress of surface water
Avoids any OH & S problems of lifting concrete or cast iron covers. Supports three times the requirement of AS/NZS1546.1:2008 Septic tanks.
The cover will deflect and then return to its original shape
The tank can be placed lower into the ground to provide better inlet grades while the access cover position is maintained at ground level
Prevents unauthorised access
'Do not leave open tank unattended' is moulded into cover
Company names and logos can be moulded on the cover

HOW TO SELECT THE TURRETS

The turrets can either be cast into a new tank lid during concrete casting, or bolted to the top of an existing lid.

TURRET ASSEMBLY CAST INTO CONCRETE TANK LID

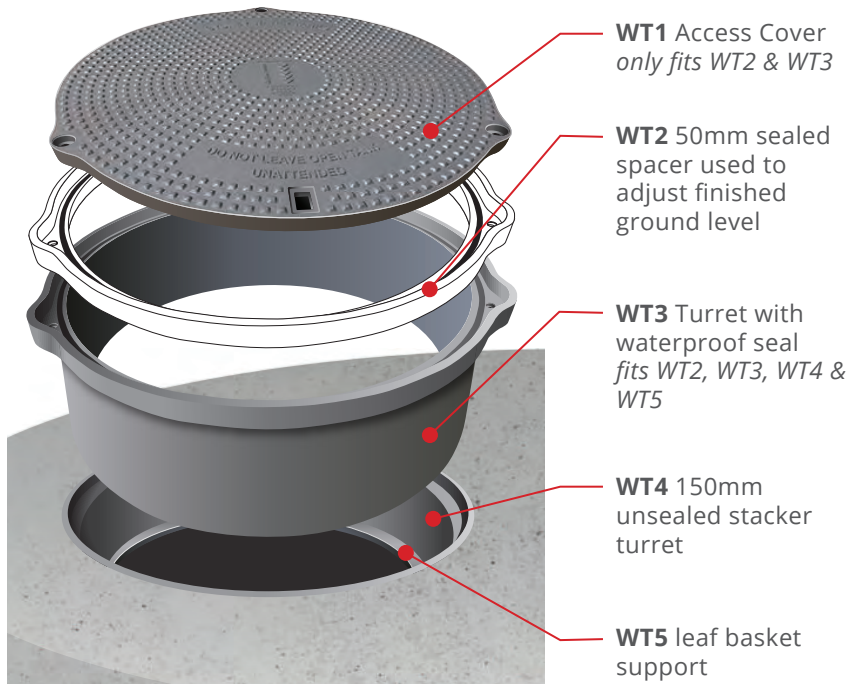

SEE OPTIONS PAGES
The overall height of the turrets can be changed by adding extra turrets. The following Options pages show various combinations.

TURRET ASSEMBLY FITTED TO AN EXISTING TANK OPENING

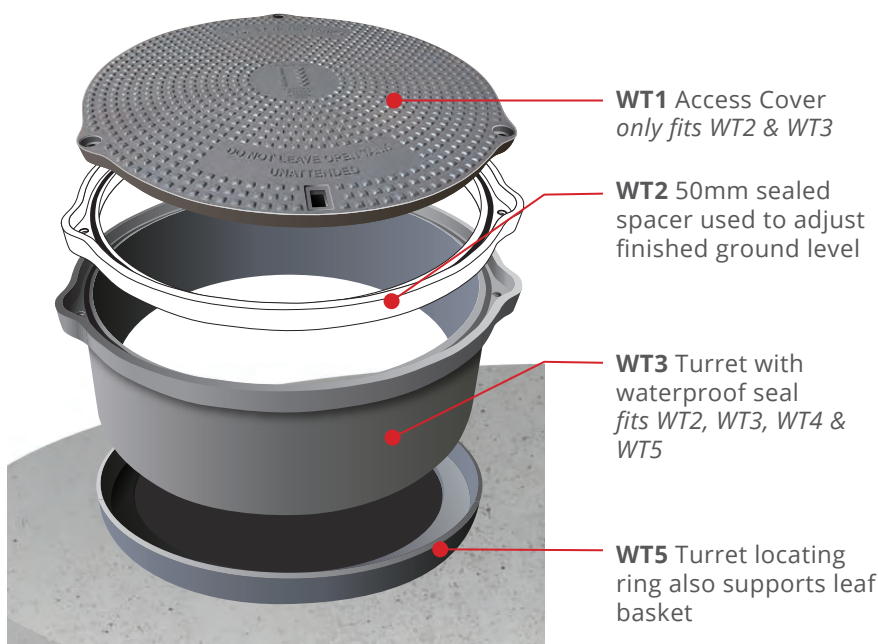

COMPONENT LIST		
	WT1	Access Cover
	WT2	50mm Sealed Riser/Spacer
	WT3	300mm Sealed Turret
	WT4	150mm Unsealed Turret
	WT5	50mm Turret locating ring also supports leaf basket

Price excludes GST

FITTING MATRIX

			Fits into from above
	WT1	Access Cover	WT2, WT3 (does NOT fit WT4, WT5)
	WT2	50mm Sealed Riser/Spacer	WT2, WT3, WT4, WT5
	WT3	300mm Sealed Turret	WT2, WT3, WT4, WT5
	WT4	150mm Unsealed Turret	WT2, WT3, WT4, WT5
	WT5	50mm Base Support Ring	No other turrets
	WTLB	Leaf Basket	WT5

TURRETS FOR NEW TANK LIDS

The WT4 unsealed turret can be cast into a 150mm thick lid. There is a 25mm rebate at the top into which the WT2, WT3 or WT4 turrets can be fitted. The actual height is 175mm high and 25mm will protrude under the lid. *Use the options 1 - 13 to obtain the required finished height above the concrete lid.*

TURRET OPTIONS WHEN CAST INTO NEW TANK LIDS

	Height (mm)	Price (without GST)
Option 1	50mm	
Option 2	100mm	
Option 3	150mm	
Option 4	200mm	
Option 5	250mm	
Option 6	300mm	
Option 7	350mm	

	Height (mm)	Price (without GST)
Option 8	400mm	
Option 9	450mm	
Option 10	500mm	
Option 11	550mm	
Option 12	600mm	
Option 13	600mm ↑	

Includes leaf basket, flap valve and 2 x 110mm holes.

OPTION 1 50mm high

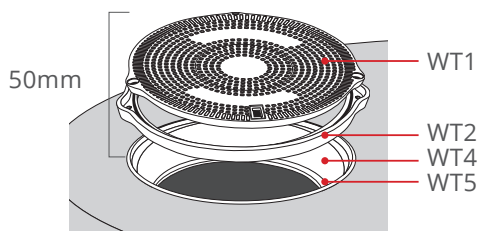

OPTION 2 100mm high

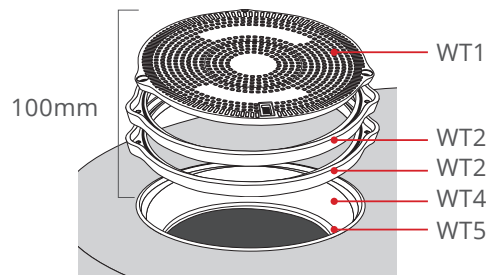



Price excludes GST

TURRETS FOR NEW TANK LIDS

OPTION 3 150mm high

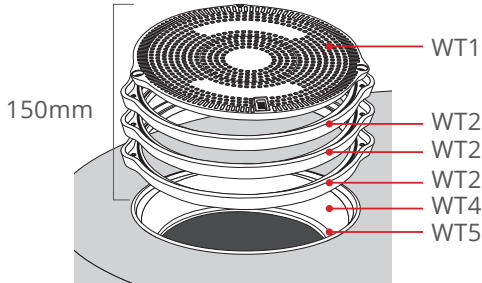

OPTION 4 200mm high

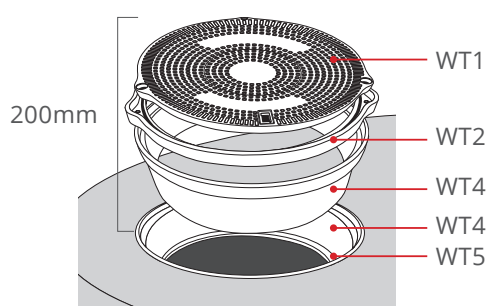

OPTION 5 250mm high

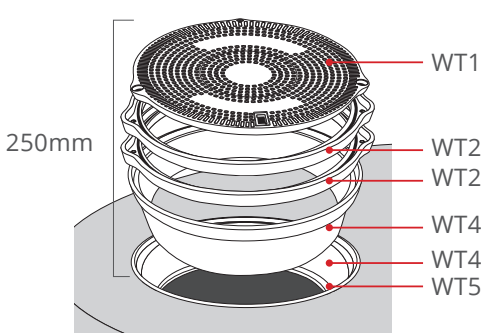

POPULAR OPTION

OPTION 6 300mm high

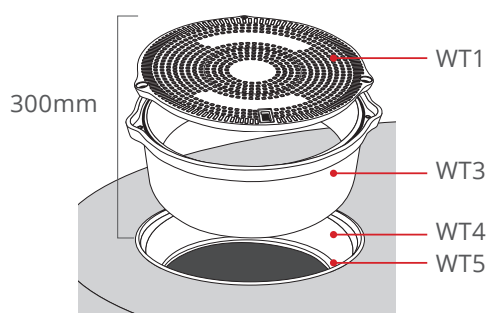

OPTION 7 350mm high

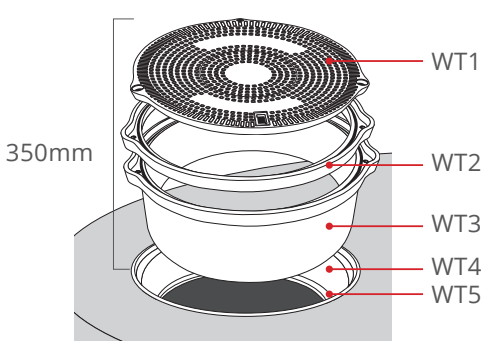

OPTION 8 400mm high

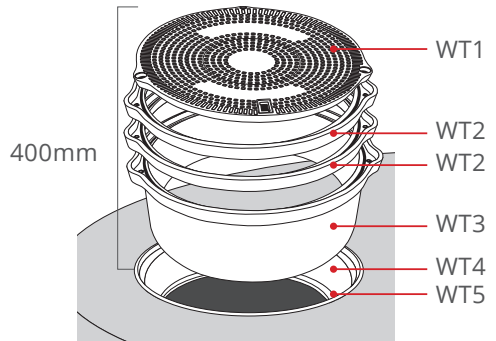

OPTION 9 450mm high

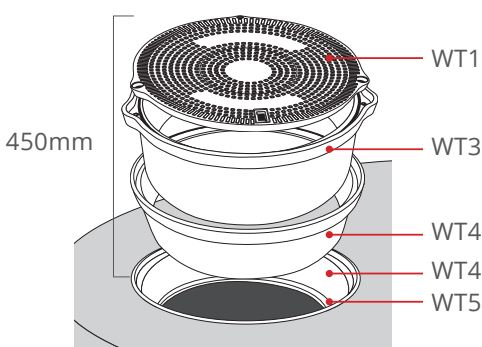

OPTION 10 500mm high

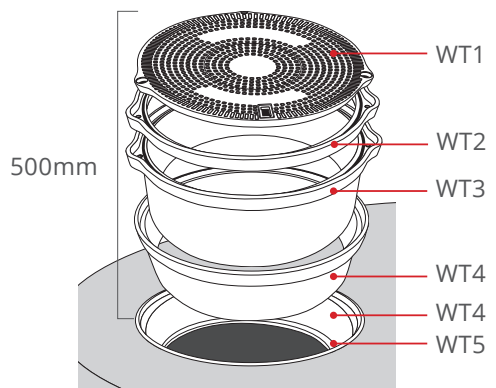

Price excludes GST

TURRETS FOR NEW TANK LIDS

OPTION 11 550mm high

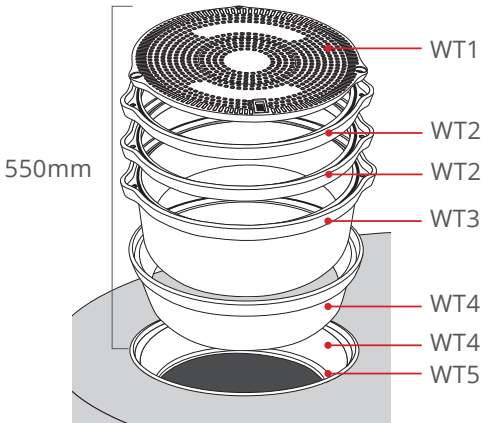

POPULAR OPTION

OPTION 12 600mm high

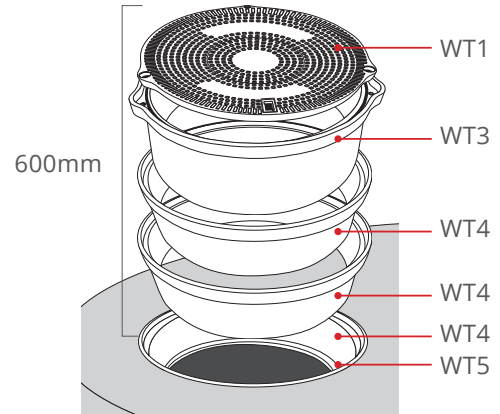

OPTION 13 Greater than 600mm high

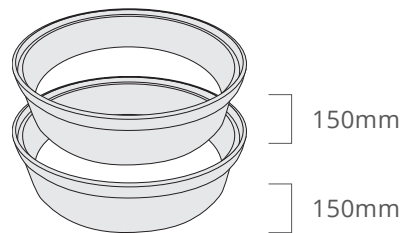
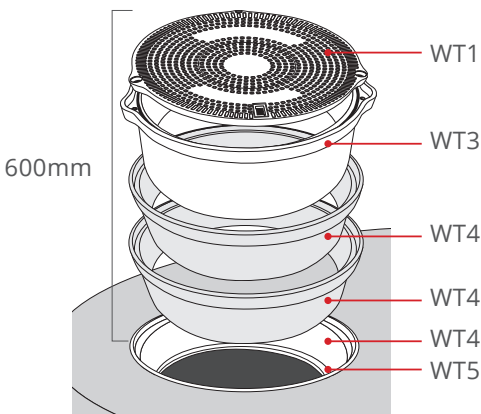

WT4 150mm turrets can be added to increase the height. Engineering advice should be sought about the capacity of the supporting tank lid.

Leaf Basket Option

If the tank inlet is through the turrets or within the concrete lid as shown in Option 14, a CONFORCE leaf basket can be located on the WT5 support ring. The basket has a cut out for the pump discharge pipe and cables to pass through the basket and exit through the turret wall.

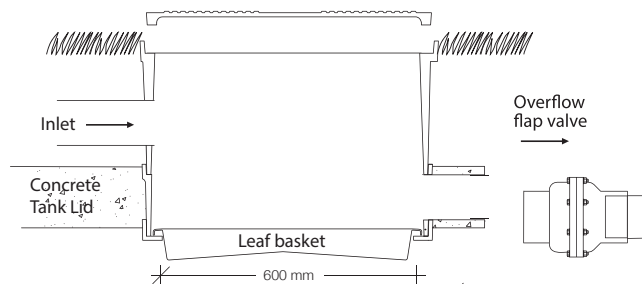
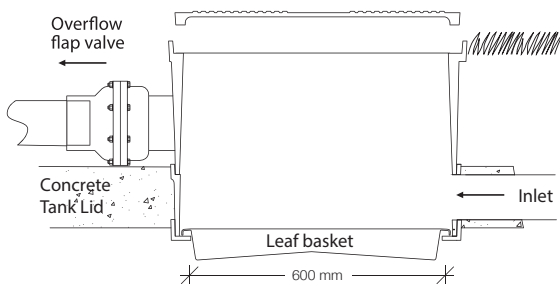



Price excludes GST

TURRETS FITTED TO EXISTING TANK LID

The WT5 base ring can be screwed or bolted to the existing tank lid into which all of the other turrets can be fitted. *Use options 14 - 25 to obtain the required finished height.*

The turrets are very heavy duty and have been used to bring to the surface access openings that are two metres below ground. The WT4 turret is used to bring the access opening to the surface and then either the WT2 turret or WT3 turret is used to provide a seal into which the WT1 access cover is bolted.

TURRET OPTIONS FOR EXISTING TANKS

	Height (mm)	Price (without GST)
Option 14	100mm	
Option 15	150mm	
Option 16	200mm	
Option 17	235mm	
Option 18	250mm	
Option 19	285mm	

	Height (mm)	Price (without GST)
Option 20	335mm	
Option 21	385mm	
Option 22	435mm	
Option 23	485mm	
Option 24	535mm	
Option 25	635mm	

OPTION 14 100mm high

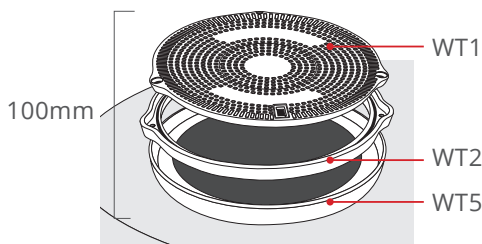

OPTION 15 150mm high

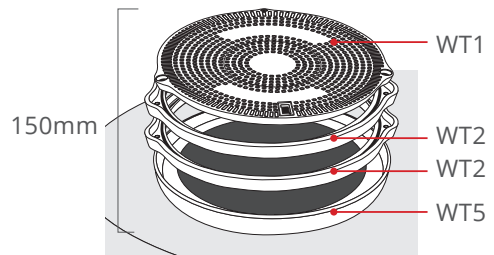

OPTION 16 200mm high

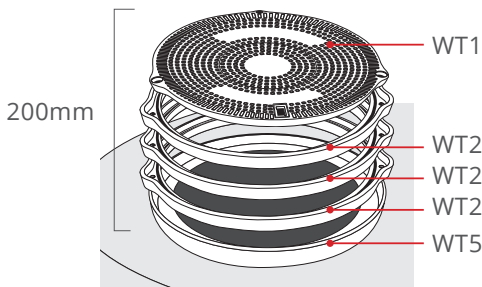

OPTION 17 235mm high

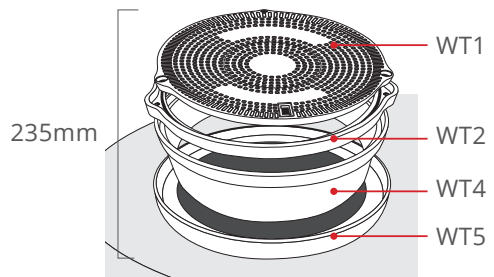

OPTION 18 250mm high

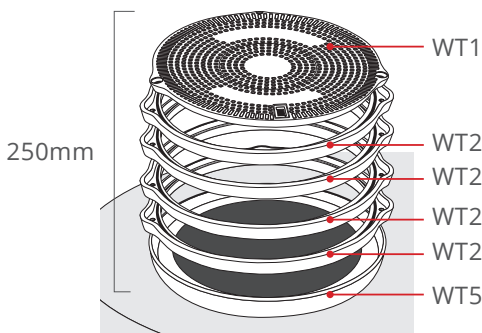

OPTION 19 285mm high

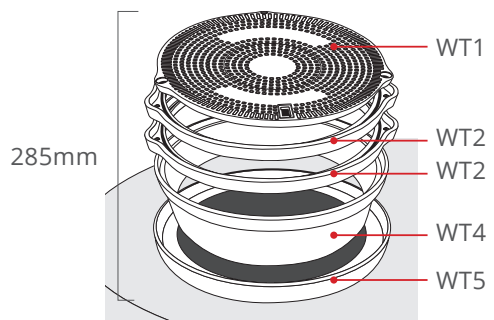



Price excludes GST

TURRETS FITTED TO EXISTING TANK LID

POPULAR OPTION

OPTION 20 335mm high

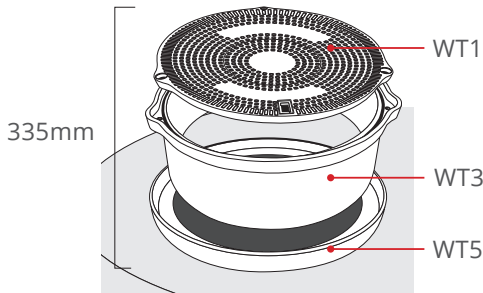

OPTION 21 385mm high

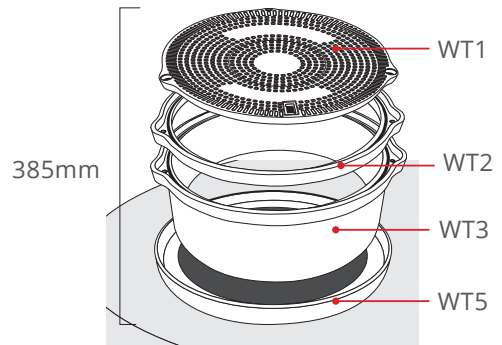

OPTION 22 435mm high

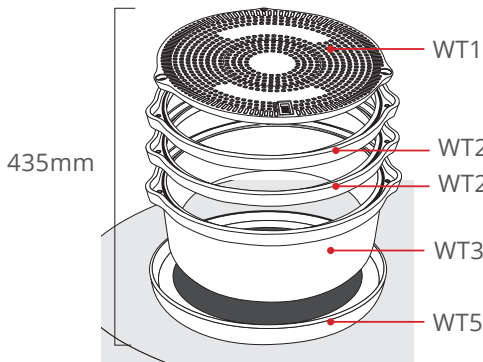

OPTION 23 485mm high

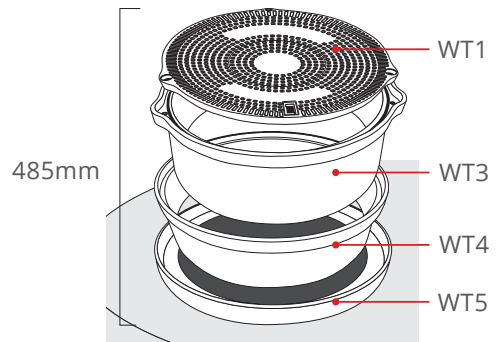

OPTION 24 535mm high

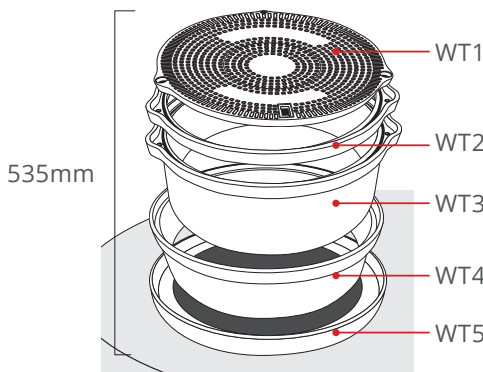

POPULAR OPTION

OPTION 25 635mm high

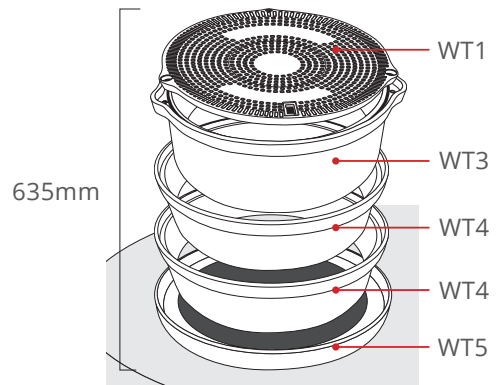

Price excludes GST

WATER TANK - WT SERIES



700mm diameter access cover

Secured by three SS bolts with sealing covers

COVER WT1



50mm Riser/spacer with waterproof seal

650mm clear opening x 50mm high

TURRET WT2



Turret with waterproof seal

650mm clear opening x 300mm high

TURRET WT3

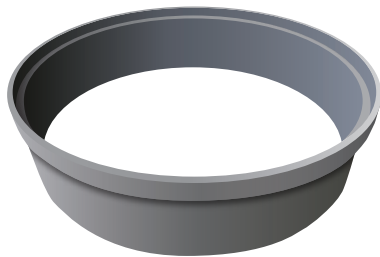

Unsealed Stacker Turret

665mm clear opening
150mm high

TURRET WT4



Base locating ring. Supports leaf basket

600mm clear opening

RING WT5

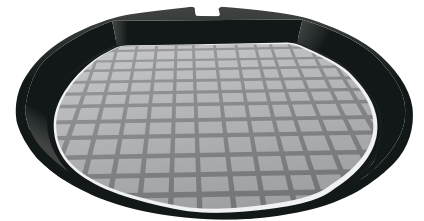

Leaf basket

1mm Mosquito screen

BASKET WTLB

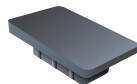
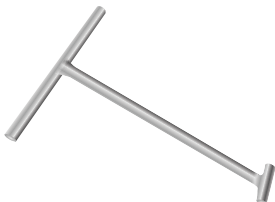

Accessories

Lifting bar

Cover for lifting bar aperture

Socket wrench

Bolts with sealing covers

Price excludes GST

UNSEALED ACCESS COVERS & FRAMES - These DO NOT fit into the WT Series turrets

FRAME OPTIONS

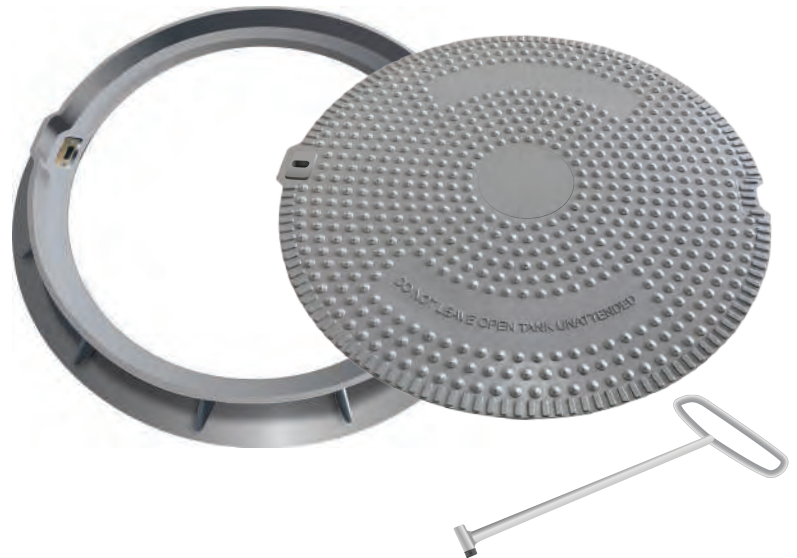
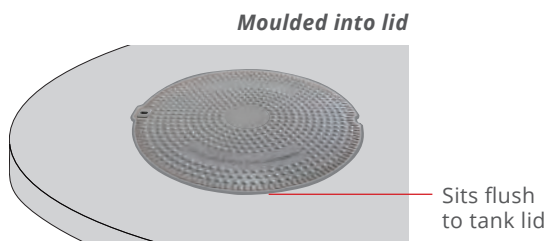
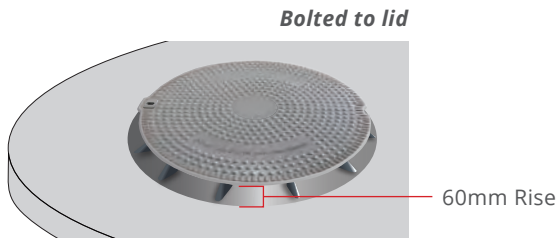

Tank access cover and frame Model No AC1/450	Tank access cover and frame Model No AC1/600
450mm clear opening	600mm clear opening

COVER BOX



Small	Large
Opening - 450mm x 400mm Overall - 500 x 450 x 350	Opening - 595mm x 445mm Overall - 650 x 500 x 370